

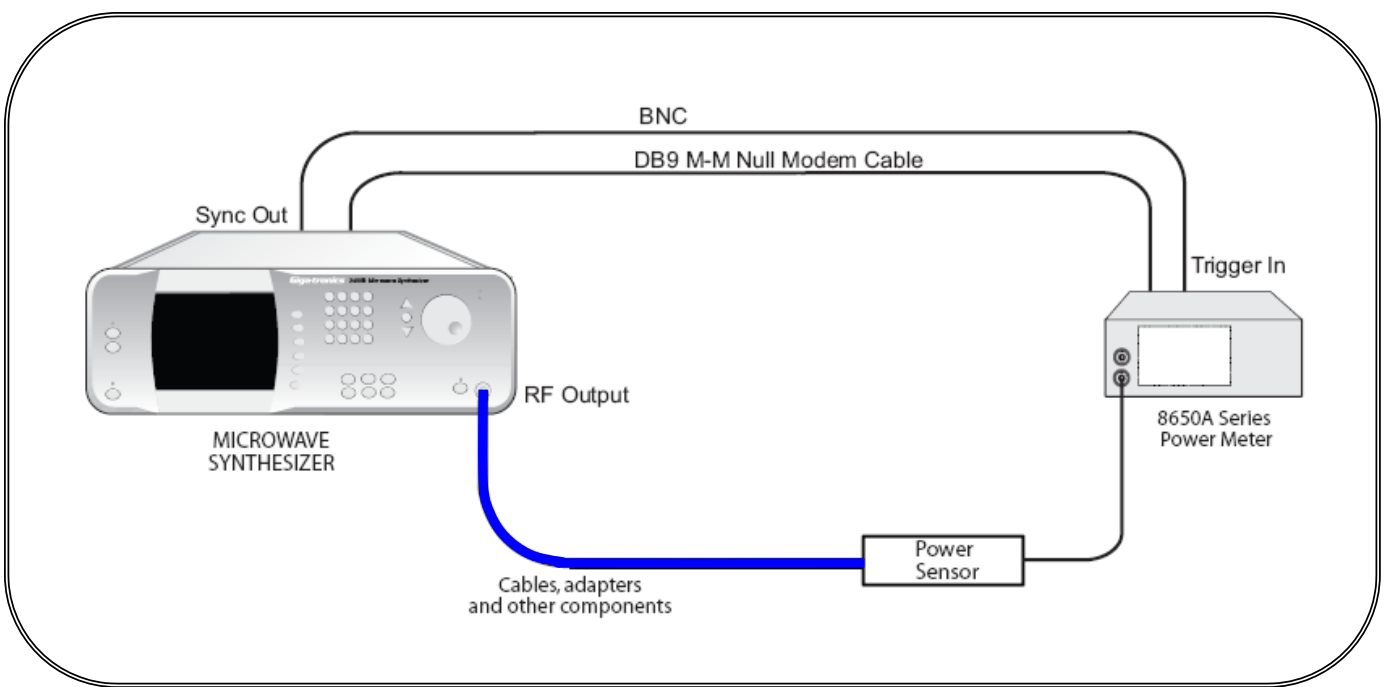

Cable Calibration Function for the 2400B and 2500A Series Microwave Signal Generators

Technical Brief

Quickly and easily apply a level correction table to compensate for external losses or power variations in an external signal path. This process takes about 30 seconds to complete.





Cable Calibration Function Overview

The Cable Cal function on the 2400B and 2500A Series Microwave Signal Generators gives you the ability to apply a level correction table to compensate for external losses or power variations in an external signal path.

When the Cable Cal function is executed on the signal generator, it will automatically control the 8650A Series power meter to measure power variations at the output of the external signal path over the full frequency range of the signal generator. The signal generator automatically puts the power meter into a Swift Buffered measurement mode, which commands the power meter to store all the measured data inside the power meter's internal data buffer until all the measurements are finished. This allows extremely fast measurements, versus that of the traditional measurement methods where a power meter would send each measurement result back to the host after each measurement.

After all the measurements have been made, the signal generator reads back the power level information from the power meter and creates a table of correction values for each frequency point. The correction table is made up of 1001 data points (frequency/amplitude data pairs). This table is stored in the signal generator's non-volatile memory. It takes about 30 seconds for the entire process to run.

Cable Losses

All cables have some amount of signal loss, which will limit system performance. Path loss usually increases with frequency and this is illustrated in figure 1 below.

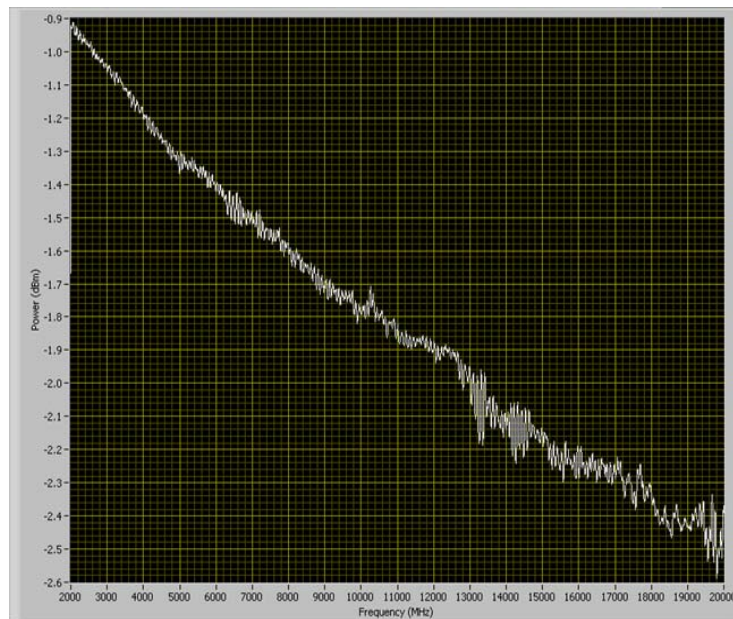

Figure 1: Cable losses without any correction applied



The graph below shows error, in dB with respect to frequency, after the Cable Calibration function has been run and the correction has been applied. As is illustrated in the graph, the error is very close ± 0.1 dB of the setting. See figure 2.

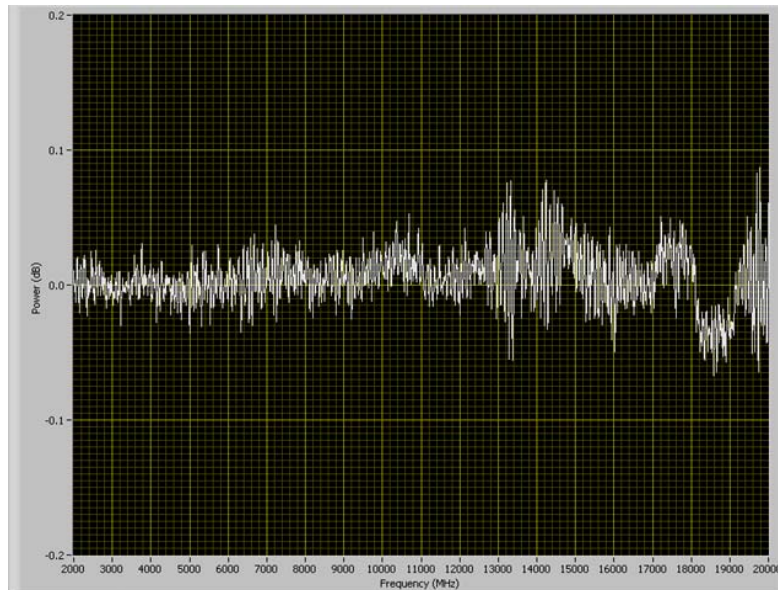

Figure 2: Error in corrected output power after the Cable Calibration correction has been applied

Figures 1 and 2 showed how much loss a cable can exhibit and how the Cable Calibration function can correct for these losses. In order to maximize system performance, it is recommended to use the Cable Calibration function to account for and correct for these losses.

Procedure to Use the Cable Calibration Function

The following steps describe the procedure for using the Cable Cal function.

Required Equipment

- 2400B or 2500A Series Signal Generator with firmware version 4.49 or higher
- 8650A Series Universal Power Meter
- Appropriate Power Sensor that covers entire frequency range
 - such as a 80303A or 80304A CW Power Sensor
- Compatible Power Sensor Cable
- BNC Male to Male Cable
- Null-Modem RS-232 Cable Male to Male



Configure the Power Meter

1. Connect the sensor to the calibrator port on the power meter. Press the “Cal/Zero” button to calibrate the sensor. See figure 3.



Figure 3: Calibrate sensor

2. Press the “Meter Setup” softkey. See figure 4.

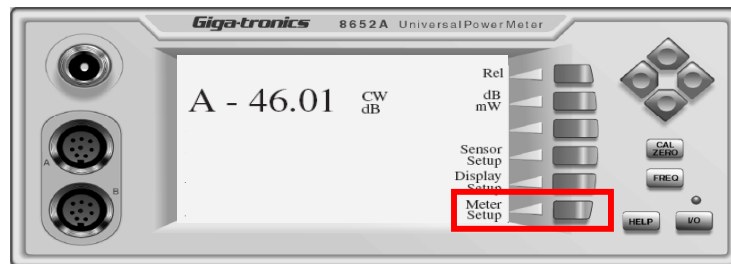

Figure 4: Setup meter



- From the Setup Menu, select the “Config” softkey. See figure 5.

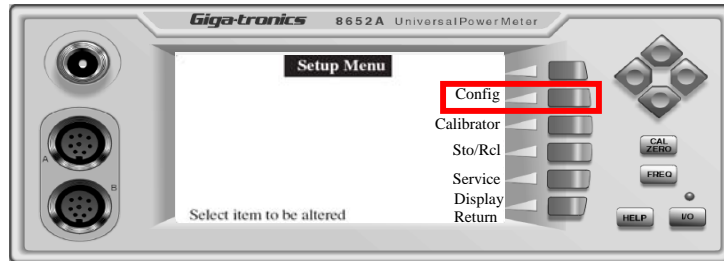

Figure 5: Configure power meter setup

- Arrow over to select RS-232. Press the “Config” soft key. See figure 6.

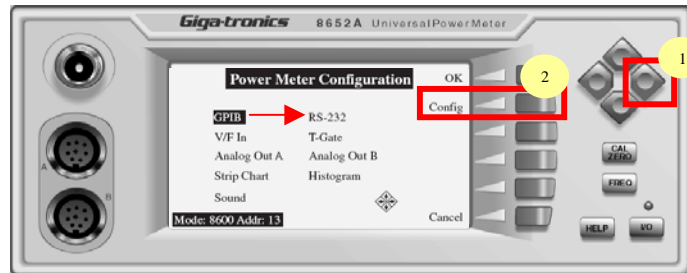

Figure 6: Select the RS-232 connection

- Set the RS-232 parameters to the following settings. Press the arrow keys to cycle through each parameter's available settings. See figure 7.
 - Baud Rate: 38400
 - Data Bits: 8
 - Parity: None
 - Stop Bits: 1



Figure 7: Configure the RS-232 settings

- Press the “OK” softkey two times to return to the main menu.

Equipment Setup

Connect the equipment as shown in Figure 8.

- Connect the null modem cable between the signal generator’s RS-232 port and the power meter’s RS-232 port.
- Connect the BNC cable from the Sync Out connector on the rear panel of the signal generator and the Trig In connector on the rear panel of the power meter.
- Connect the sensor to the RF path to be characterized.

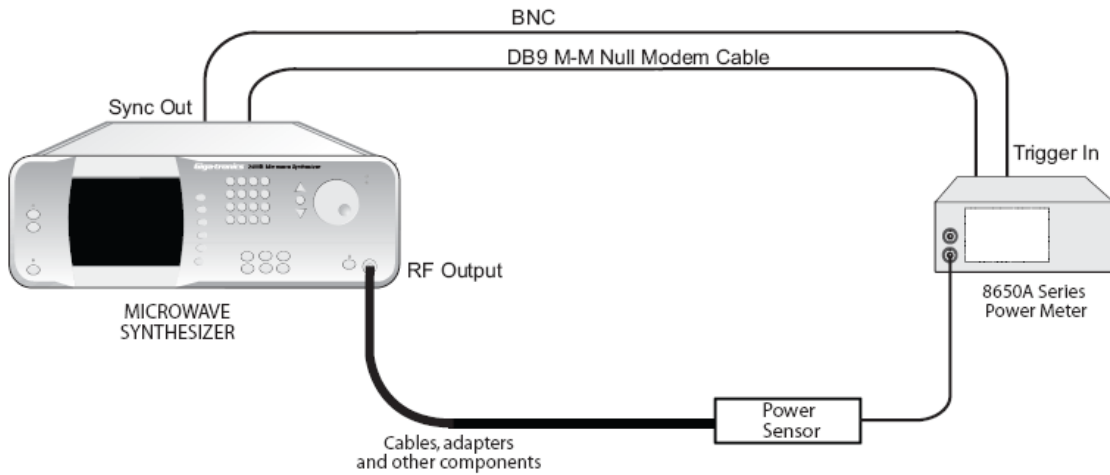

Figure 8: Cable Cal Equipment Setup

Configure the Signal Generator

- From the CW menu, press the “Cable Cal Menu” softkey. See figure 9.

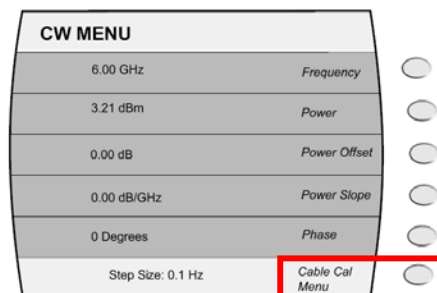

Figure 9

- Press the “To Cable Cal Execution Menu” softkey. See figure 10.

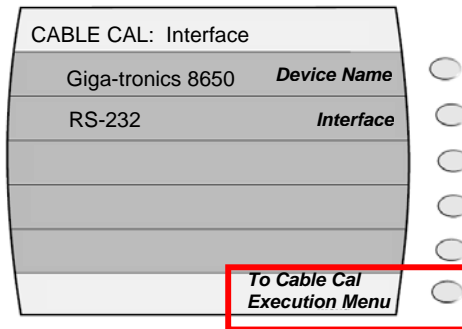

Figure 10

- Press “Start Cable Cal” softkey to begin the swept frequency characterization. See figure 11.

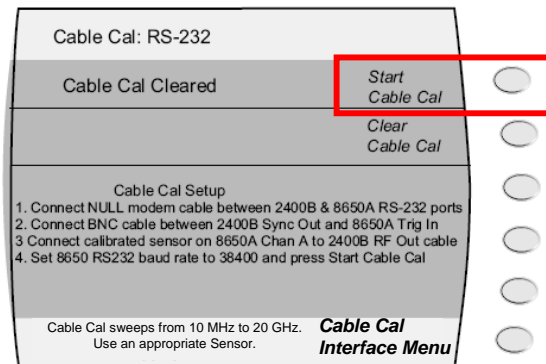

Figure 11

A progress bar is displayed on the signal generator’s front panel during the calibration. A message at the bottom of the screen indicates that the Cable Cal is in process. See figure 12. The Cable Cal function creates a table of 1001 of correction points. Each correction point consists of a frequency and amplitude correction value for that frequency. Level corrections for frequency values between correction points are determined by using a linear algorithm.

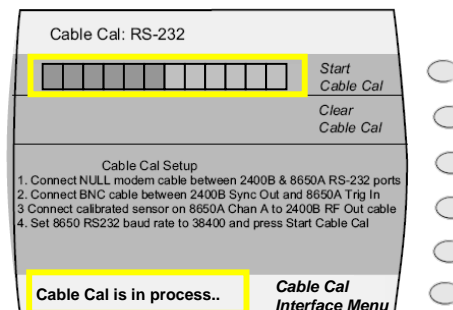

Figure 12



The signal generator will start communicating with the power meter and will put it into the “Swift buffered mode”. See figure 13.



Figure 13

After the frequency sweep is completed, a cable correction table will be generated and stored in the signal generator’s non-volatile memory. The first line in the Cable Cal menu will change to “Cable Cal Stored”. A message at the bottom of the screen will display “Cable Cal is complete”. See figure 14.

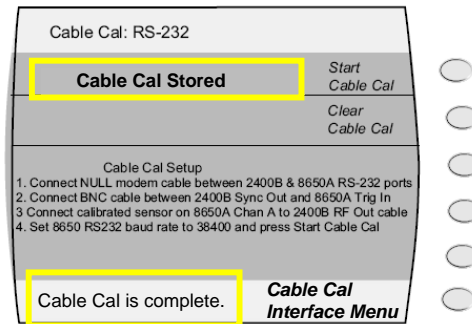

Figure 14

After the Cable Cal routine is run, you may now remove the power meter and power sensor from your measurement setup. These correction factors will automatically applied to the output of the signal generator. If there are any changes made to the external signal path, then the power meter and sensor should be reconnected as shown in figure 7, and the “Cable Cal” function should be re-run. This will overwrite any previous correction data with the new data.

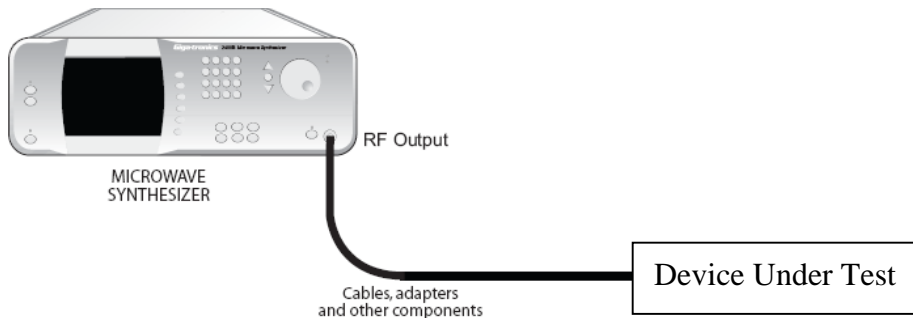

Figure 15: Cable Cal applied to correct for external path losses.



The cable calibration will apply to the output of the signal generator until the “Clear Cable Cal” softkey is pressed. See figure 16.

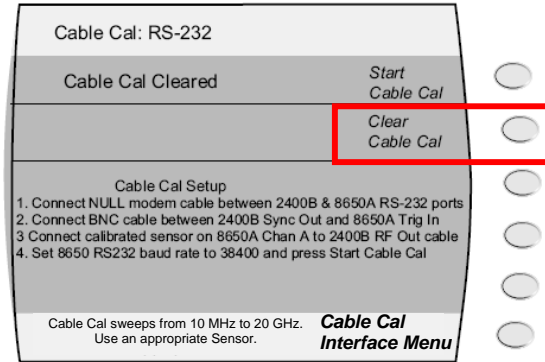

Figure 16

Summary

All cables experience some amount of loss that will vary with respect to its length and the frequency of the signal passing through it. Any losses in the pass will degrade system performance. It is recommended to use the Cable Cal function to quickly and easily characterize external path losses and correct for them.